

CROWN

FC 5200 SERIES

Specifications
Sit-Down Rider Lift Truck

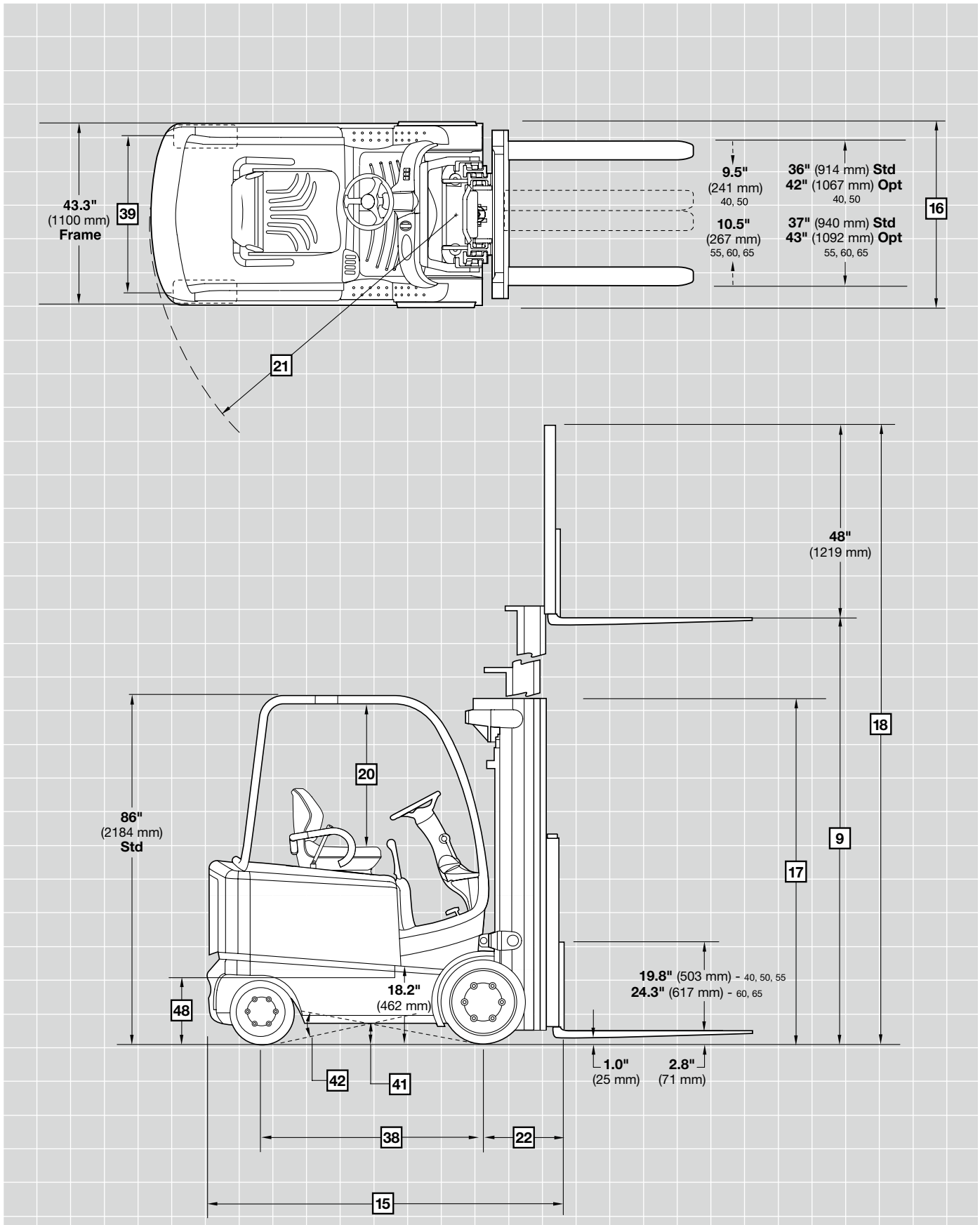



FC 5200 Series

Specifications

			Imperial	Metric	Imperial	Metric		
General Information	1	Manufacturer	Crown Equipment Corporation					
	2	Model	FC 5215-40					
	3	Load Capacity*	lb kg	4000	1810	4000	1810	
	4	Load Center	Fork Face to Load CG	in mm	24	600	24	600
	5	Power	Electric	36-Volt / 48-Volt				
	6	Operator Type	Sit-down Rider Counterbalanced					
	7	Tire Type	Cushion					
	8	Wheels (x = driven)	Number Front/Rear	2x/2				
Dimensions	9	Mast (See Mast Chart)	Lifting Height (MFH)	in mm	188	4775	188	4775
			Free Lift Height	in mm	32.2	815	32.2	815
	12	Fork Carriage	ITA Class II					
	13	Forks	Standard L x W x T	in mm	36x4x1.8	915x102x46	36x4x1.8	915x102x46
			Optional Lengths	in mm	30, 32, 40, 42, 48, 54, 60, 72	760, 815, 1015, 1065, 1220, 1370, 1525, 1825	30, 32, 40, 42, 48, 54, 60, 72	760, 815, 1015, 1065, 1220, 1370, 1525, 1825
	14	Tilt	F° / B°	degree	5 / 5			
			Interlocked Fork Height**	in mm	66	1675	66	1675
		Battery Compartment	Nominal	in mm	27	686	33	838
	15	Headlength	Length to Fork Face	in mm	78.4	1990	84.6	2150
	16	Width Overall	Standard Tread	in mm	43.9	1115	43.9	1115
			Wide Tread	in mm	47.5	1210	47.5	1210
	17	Height with Load Backrest	Mast Collapsed	in mm	83	2105	83	2105
	18		Mast Extended	in mm	236	5995	236	5995
	20	SIP to Bottom of OHG (86" [2184 mm] Tall OHG)	Std / Suspension	in mm	36.1/35.8	918/910	36.1/35.8	918/910
	21	Turning Radius		in mm	66.6	1690	72.1	1830
22	Load Distance	Center of Wheel to Fork Face	in mm	15.8	400	15.8	400	
23	Aisle Width (Add Load + Clear)	Right Angle Stack	in mm	82.4	2090	87.9	2230	
Performance	24	Speed Travel	Empty / Loaded 48V	mph km/h	12.3/11.0	19.7/17.7	12.3/11.0	19.7/17.7
			Empty / Loaded 36V	mph km/h	11.0/10.0	17.7/16.1	11.0/10.0	17.7/16.1
	25	Speed Lift†	Empty / Loaded 48V	fpm mm/s	115/113	584/573	115/113	584/573
			Empty / Loaded 36V	fpm mm/s	115/86	584/438	115/86	584/438
26	Speed Lower	Empty / Loaded (Manual Hyd)	fpm mm/s	90	460	90	460	
		Empty / Loaded (EPV Hyd)	fpm mm/s	100	505	100	505	
Weights	32	Weight, Less Battery	lb kg	7240	3285	7325	3320	
	33	Axle Load with Max Battery, Loaded	Front	lb kg	12034	5451	12060	5462
			Rear	lb kg	2406	1094	3265	1483
	34	Axle Load with Max Battery, Unloaded	Front	lb kg	4831	2192	5149	2335
Rear			lb kg	5609	2543	6176	2800	
Chassis	36	Tires	Size Front	in mm	21x7x15	533x178x381	21x7x15	533x178x381
	37		Size Rear	in mm	16x6x10.5	406x152x267	16x6x10.5	406x152x267
	38	Wheelbase		in mm	49.7	1260	54.7	1390
	39	Tread/Track Width	Front Standard / Rear	in mm	36.9/36	937/914	36.9/36	937/914
			Front Optional / Rear	in mm	40.5/36	1029/914	40.5/36	1029/914
	40	Ground Clearance, Loaded	Lowest Point	in mm	3	76	3	76
	41		Center of Wheelbase	in mm	4.8	122	4.8	122
	42	Grade Clearance, Loaded		%	38		35	
43	Brakes	Service	Foot Motor - Electric Assist					
44		Parking	Auto - Electric					
Battery	45	Battery††	Type	Lead Acid				
			Capacity - 36V 5hr Rating @ 30°C	AH	1180		1400	
	46		Capacity - 36V 6hr Rating @ 25°C	AH	1210		1430	
				kWh	42.5		50.2	
	47		Capacity - 48V 5hr Rating @ 30°C	AH	860		1075	
			Capacity - 48V 6hr Rating @ 25°C	AH	880		1100	
				kWh	41.2		51.5	
	48	Battery Floor Height	Weight - Min	lb kg	2630	1195	2800	1270
			Weight - Max	lb kg	3200	1450	4000	1815
	49	Motors	Dual Tractor Motors, dia	in mm	8.9	225	8.9	225
Lift Motor, dia			in mm	7.2	183	7.2	183	
Size - Max			Length	27.25	692	32.94	837	
			Width	38.69	983	38.69	983	
50			Height	22.25	565	22.25	565	
		Cable Lead Length/Connector Pos.	in mm	18/A	455/A	18/A	455/A	
51	Operating Pressure	For Attachments	psi bar	Up to 3000	Up to 207	Up to 3000	Up to 207	

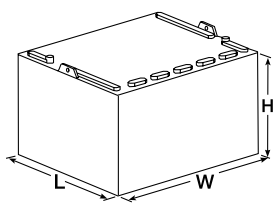

* Optional masts, attachments, longer load dimensions and higher lifting heights may result in derating of the capacity. Contact local dealer.
 ** Forward tilt restricted to 2° above this height.
 † Based on TT mast.
 †† With maintenance-free batteries or batteries with a lid (flat top), consult factory.

FC 5200 Series

Specifications

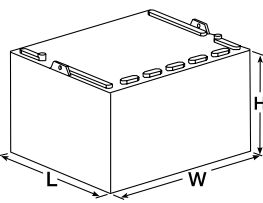
			<i>Imperial</i>	<i>Metric</i>	<i>Imperial</i>	<i>Metric</i>		
General Information	1	Manufacturer	Crown Equipment Corporation					
	2	Model	FC 5215-50		FC 5225-50			
	3	Load Capacity*	lb	kg	5000	2265		
	4	Load Center	Fork Face to Load CG	in	mm	24	600	
	5	Power	Electric	36-Volt / 48-Volt				
	6	Operator Type	Sit-down Rider Counterbalanced					
	7	Tire Type	Cushion					
	8	Wheels (x = driven)	Number Front/Rear	2x/2				
Dimensions	9	Mast (See Mast Chart)	Lifting Height (MFH)	in	mm	188	4775	
			Free Lift Height	in	mm	32.2	815	
	12	Fork Carriage	ITA Class II					
	13	Forks	Standard L x W x T	in	mm	36x4x1.8	915x102x46	
			Optional Lengths	in	mm	30, 32, 40, 42, 48, 54, 60, 72	760, 815, 1015, 1065, 1220, 1370, 1525, 1825	
	14	Tilt	F° / B°	degree	5 / 5			
			Interlocked Fork Height**	in	mm	66	1675	
		Battery Compartment	Nominal	in	mm	27	686	
	15	Headlength	Length to Fork Face	in	mm	81.4	2070	
	16	Width Overall	Standard Tread	in	mm	43.9	1115	
			Wide Tread	in	mm	47.5	1210	
	17	Height with Load Backrest	Mast Collapsed	in	mm	83	2105	
	18		Mast Extended	in	mm	236	5995	
	20	SIP to Bottom of OHG (86" [2184 mm] Tall OHG)	Std / Suspension	in	mm	36.1/35.8	918/910	
	21	Turning Radius		in	mm	69.3	1760	
22	Load Distance	Center of Wheel to Fork Face	in	mm	15.8	400		
23	Aisle Width (Add Load + Clear)	Right Angle Stack	in	mm	85.1	2160		
Performance	24	Speed Travel	Empty / Loaded 48V	mph	km/h	12.3/11.0	19.7/17.7	
			Empty / Loaded 36V	mph	km/h	11.0/10.0	17.7/16.1	
	25	Speed Lift†	Empty / Loaded 48V	fpm	mm/s	115/102	584/520	
			Empty / Loaded 36V	fpm	mm/s	115/75	584/381	
26	Speed Lower	Empty / Loaded (Manual Hyd)	fpm	mm/s	90	460		
		Empty / Loaded (EPV Hyd)	fpm	mm/s	100	505		
Weights	32	Weight, Less Battery	lb	kg	8090	3670		
	33	Axle Load with Max Battery, Loaded	Front	lb	kg	13657	6189	
			Rear	lb	kg	2633	1196	
	34	Axle Load with Max Battery, Unloaded	Front	lb	kg	4653	2110	
Rear			lb	kg	6637	3010		
Chassis	36	Tires	Size Front	in	mm	21x7x15	533x178x381	
	Size Rear		in	mm	16x6x10.5	406x152x267		
	38	Wheelbase	in	mm	49.7	1260		
	39	Tread/Track Width	Front Standard / Rear	in	mm	36.9/36	937/914	
			Front Optional / Rear	in	mm	40.5/36	1029/914	
	40	Ground Clearance, Loaded	Lowest Point	in	mm	3	76	
	41		Center of Wheelbase	in	mm	4.8	122	
	42	Grade Clearance, Loaded	%			38	35	
43	Brakes	Service	Foot Motor - Electric Assist					
44		Parking	Auto - Electric					
Battery	45		Type	Lead Acid				
	46		Capacity - 36V 5hr Rating @ 30°C	AH	1180		1400	
			Capacity - 36V 6hr Rating @ 25°C	AH	1210		1430	
	47		Capacity - 48V 5hr Rating @ 30°C	kWh	42.5		50.2	
			Capacity - 48V 6hr Rating @ 25°C	AH	860		1075	
	48		Capacity - 48V 6hr Rating @ 25°C	AH	880		1100	
				kWh	41.2		51.5	
			Weight - Min	lb	kg	2630	1195	2800
			Weight - Max	lb	kg	3200	1450	4000
	49		Motors	Dual Tractor Motors, dia	in	mm	8.9	225
Lift Motor, dia		in		mm	7.2	183		
		Length		in	mm	27.25	692	
		Width		in	mm	38.69	983	
50	Operating Pressure		Height	in	mm	22.25	565	
			Cable Lead Length/Connector Pos.	in	mm	18/A	455/A	
51	Motors	With Rollers / w/o Rollers	in	mm	17.4/17.1	442/434		
Motors	Motors	Dual Tractor Motors, dia	in	mm	8.9	225		
		Lift Motor, dia	in	mm	7.2	183		
		Operating Pressure	psi	bar	Up to 3000	Up to 207	Up to 3000	

* Optional masts, attachments, longer load dimensions and higher lifting heights may result in derating of the capacity. Contact local dealer.

** Forward tilt restricted to 2° above this height.

† Based on TT mast.

†† With maintenance-free batteries or batteries with a lid (flat top), consult factory.

FC 5200 Series

Specifications

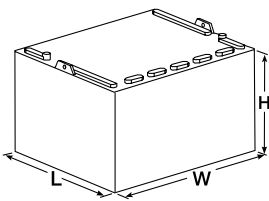
			Imperial	Metric	Imperial	Metric			
General Information	1	Manufacturer	Crown Equipment Corporation						
	2	Model	FC 5245-50						
	3	Load Capacity*	lb kg	5000 2265	FC 5225-55				
	4	Load Center	Fork Face to Load CG	in mm	24 600	24 600			
	5	Power	Electric	36-Volt / 48-Volt					
	6	Operator Type	Sit-down Rider Counterbalanced						
	7	Tire Type	Cushion						
	8	Wheels (x = driven)	Number Front/Rear	2x/2					
Dimensions	9	Mast (See Mast Chart)	Lifting Height (MFH)	in mm	188 4775	188 4775			
			Free Lift Height	in mm	32.2 815	32.2 815			
	12	Fork Carriage	ITA Class II						
	13	Forks	Standard L x W x T	in mm	36x4x1.8 915x102x46	36x5x1.8 915x127x46			
			Optional Lengths	in mm	30, 32, 40, 42, 48, 54, 60, 72	760, 815, 1015, 1065, 1220, 1370, 1525, 1825	30, 40, 42, 48, 54, 60, 72	760, 1015, 1065, 1220, 1370, 1525, 1825	
	14	Tilt	F° / B°	degree	5 / 5				
			Interlocked Fork Height**	in mm	66 1675	66 1675			
		Battery Compartment	Nominal	in mm	36 914	33 838			
	15	Headlength	Length to Fork Face	in mm	87.7 2230	87.6 2225			
	16	Width Overall	Standard Tread	in mm	43.9 1115	45.7 1160			
			Wide Tread	in mm	47.5 1210	48 1220			
	17	Height with Load Backrest	Mast Collapsed	in mm	83 2105	83 2105			
	18		Mast Extended	in mm	236 5995	236 5995			
	20	SIP to Bottom of OHG (86" [2184 mm] Tall OHG)	Std / Suspension	in mm	36.1/35.8 918/910	36.1/35.8 918/910			
	21	Turning Radius		in mm	74.9 1905	74.9 1905			
22	Load Distance	Center of Wheel to Fork Face	in mm	15.8 400	15.8 400				
23	Aisle Width (Add Load + Clear)	Right Angle Stack	in mm	90.7 2305	90.7 2315				
Performance	24	Speed Travel	Empty / Loaded 48V	mph km/h	12.3/11.0 19.7/17.7	12.3/11.0 19.7/17.7			
			Empty / Loaded 36V	mph km/h	11.0/10.0 17.7/16.1	11.0/10.0 17.7/16.1			
	25	Speed Lift†	Empty / Loaded 48V	fpm mm/s	115/102 584/520	115/97 584/493			
			Empty / Loaded 36V	fpm mm/s	115/75 584/381	115/69 584/351			
26	Speed Lower	Empty / Loaded (Manual Hyd)	fpm mm/s	90 460	90 460				
		Empty / Loaded (EPV Hyd)	fpm mm/s	100 505	100 505				
Weights	32	Weight, Less Battery	lb kg	7580 3440	8405 3810				
	33	Axle Load with Max Battery, Loaded	Front	lb kg	13695 6209	14593 6610			
			Rear	lb kg	3135 1426	3312 1505			
	34	Axle Load with Max Battery, Unloaded	Front	lb kg	5057 2296	5091 2308			
Rear			lb kg	6773 3074	7314 3317				
Chassis	36	Tires	Size Front	in mm	21x7x15 533x178x381	21x8x15 533x203x381			
	Size Rear		in mm	16x6x10.5 406x152x267	16x6x10.5 406x152x267				
	38	Wheelbase	in mm	54.7 1390	54.7 1390				
	39	Tread/Track Width	Front Standard / Rear	in mm	36.9/36 937/914	37.9/36 965/914			
			Front Optional / Rear	in mm	40.5/36 1029/914	39.5/36 1005/914			
	40	Ground Clearance, Loaded	Lowest Point	in mm	3 76	3 76			
	41		Center of Wheelbase	in mm	4.8 122	4.8 122			
	42	Grade Clearance, Loaded	%	35 35					
43	Brakes	Service	Foot Motor - Electric Assist						
44		Parking	Auto - Electric						
Battery	45	Battery††	Type	Lead Acid					
			Capacity - 36V 5hr Rating @ 30°C	AH	1615		1400		
	46		Capacity - 36V 6hr Rating @ 25°C	AH	1650		1430		
				kWh	57.9		50.2		
			Capacity - 48V 5hr Rating @ 30°C	AH	1180		1075		
			Capacity - 48V 6hr Rating @ 25°C	AH	1210		1100		
	47				in mm	56.6		51.5	
				Weight - Min	lb kg	3100 1410		2800 1270	
				Weight - Max	lb kg	4250 1930		4000 1815	
				Size - Max	Length	in mm	36.38 924		32.94 837
Width					in mm	38.69 983		38.69 983	
Height				in mm	22.25 565		22.25 565		
48	Battery Floor Height	Cable Lead Length/Connector Pos.	in mm	18/A 455/A	18/A 455/A				
Motors	49	Motors	With Rollers / w/o Rollers	in mm	17.4/17.1 442/434	17.4/17.1 442/434			
	50		Dual Tractor Motors, dia	in mm	8.9 225	8.9 225			
	51		Lift Motor, dia	in mm	7.2 183	7.2 183			
51	Operating Pressure	For Attachments	psi bar	Up to 3000 Up to 207	Up to 3000 Up to 207				

* Optional masts, attachments, longer load dimensions and higher lifting heights may result in derating of the capacity. Contact local dealer.

** Forward tilt restricted to 2° above this height.

† Based on TT mast.

†† With maintenance-free batteries or batteries with a lid (flat top), consult factory.

FC 5200 Series

Specifications

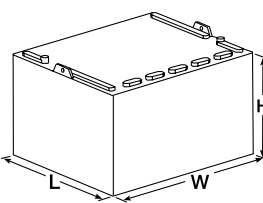
			Imperial	Metric	Imperial	Metric		
General Information	1	Manufacturer	Crown Equipment Corporation					
	2	Model	FC 5245-55		FC 5225-60			
	3	Load Capacity*	lb kg	5500 2490	6000 2720			
	4	Load Center	Fork Face to Load CG	in mm	24 600	24 600		
	5	Power	Electric	36-Volt / 48-Volt				
	6	Operator Type	Sit-down Rider Counterbalanced					
	7	Tire Type	Cushion					
	8	Wheels (x = driven)	Number Front/Rear	2x/2				
Dimensions	9	Mast (See Mast Chart)	Lifting Height (MFH)	in mm	188 4775	180 4570		
			Free Lift Height	in mm	32.2 815	32.2 815		
	12	Fork Carriage			ITA Class II	ITA Class III		
	13	Forks	Standard L x W x T	in mm	36x5x1.8 915x127x46	36x5x1.8 915x127x46		
			Optional Lengths	in mm	30, 40, 42, 48, 54, 60, 72	760, 1015, 1065, 1220, 1370, 1525, 1825	40, 42, 48, 54, 60, 72	1015, 1065, 1220, 1370, 1525, 1825
	14	Tilt	F° / B°	degree	5 / 5			
			Interlocked Fork Height**	in mm	66 1675	66 1675		
		Battery Compartment	Nominal	in mm	36 914	33 838		
	15	Headlength	Length to Fork Face	in mm	90.7 2305	87.9 2235		
	16	Width Overall	Standard Tread	in mm	45.7 1160	45.7 1160		
			Wide Tread	in mm	48 1220	48 1220		
	17	Height with Load Backrest	Mast Collapsed	in mm	83 2105	83 2105		
	18		Mast Extended	in mm	236 5995	228 5795		
	20	SIP to Bottom of OHG (86" [2184 mm] Tall OHG)	Std / Suspension	in mm	36.1/35.8 918/910	36.1/35.8 918/910		
	21	Turning Radius		in mm	77.7 1975	74.9 1905		
	22	Load Distance	Center of Wheel to Fork Face	in mm	15.8 400	16.1 410		
	23	Aisle Width (Add Load + Clear)	Right Angle Stack	in mm	93.5 2385	91 2315		
	Performance	24	Speed Travel	Empty / Loaded 48V	mph km/h	12.3/11.0 19.7/17.7	12.3/11.0 19.7/17.7	
				Empty / Loaded 36V	mph km/h	11.0/10.0 17.7/16.1	11.0/10.0 17.7/16.1	
		25	Speed Lift†	Empty / Loaded 48V	fpm mm/s	115/97 584/493	115/92 584/467	
Empty / Loaded 36V				fpm mm/s	115/69 584/351	115/64 584/327		
26		Speed Lower	Empty / Loaded (Manual Hyd)	fpm mm/s	90 460	90 460		
			Empty / Loaded (EPV Hyd)	fpm mm/s	100 505	100 505		
Weights	32	Weight, Less Battery	lb kg	8305 3770	8795 3990			
	33	Axle Load with Max Battery, Loaded	Front	lb kg	14362 6509	15656 7099		
			Rear	lb kg	3693 1681	3139 1426		
	34	Axle Load with Max Battery, Unloaded	Front	lb kg	4860 2207	5257 2385		
Rear			lb kg	7695 3493	7538 3420			
Chassis	36	Tires	Size Front	in mm	21x8x15 533x203x381	21x8x15 533x203x381		
	Size Rear		in mm	16x6x10.5 406x152x267	16x6x10.5 406x152x267			
	38	Wheelbase	in mm	54.7 1390	54.7 1390			
	39	Tread/Track Width	Front Standard / Rear	in mm	37.9/36 965/914	37.9/36 965/914		
			Front Optional / Rear	in mm	39.5/36 1005/914	39.5/36 1005/914		
	40	Ground Clearance, Loaded	Lowest Point	in mm	3 76	3 76		
	Center of Wheelbase		in mm	4.8 122	4.8 122			
	42	Grade Clearance, Loaded	%	35		35		
	43	Brakes	Service	Foot Motor - Electric Assist				
	44		Parking	Auto - Electric				
Battery	45	Battery†† 	Type	Lead Acid				
	46		Capacity - 36V 5hr Rating @ 30°C	AH	1615		1400	
			Capacity - 36V 6hr Rating @ 25°C	AH	1650		1430	
				kWh	57.9		50.2	
			Capacity - 48V 5hr Rating @ 30°C	AH	1180		1075	
			Capacity - 48V 6hr Rating @ 25°C	AH	1210		1100	
				kWh	56.6		51.5	
	47		Weight - Min	lb kg	3100 1410	2800 1270		
			Weight - Max	lb kg	4250 1930	4000 1850		
			Size - Max	Length	36.38 924	32.94 837		
Width		38.69 983		38.69 983				
	Height	22.25 565	22.25 565					
	Cable Lead Length/Connector Pos.	in mm	18/A 455/A	18/A 455/A				
48	Battery Floor Height	With Rollers / w/o Rollers	in mm	17.4/17.1 442/434	17.4/17.1 442/434			
Motors	49	Motors	Dual Tractor Motors, dia	in mm	8.9 225	8.9 225		
	50		Lift Motor, dia	in mm	7.2 183	7.2 183		
51	Operating Pressure	For Attachments	psi bar	Up to 3000 Up to 207	Up to 3000 Up to 207			

* Optional masts, attachments, longer load dimensions and higher lifting heights may result in derating of the capacity. Contact local dealer.

** Forward tilt restricted to 2° above this height.

† Based on TT mast.

†† With maintenance-free batteries or batteries with a lid (flat top), consult factory.

FC 5200 Series

Specifications

				Imperial	Metric	Imperial	Metric
General Information	1	Manufacturer		Crown Equipment Corporation			
	2	Model		FC 5245-60		FC 5245-65	
	3	Load Capacity*	lb kg	6000	2720	6500	2945
	4	Load Center	Fork Face to Load CG in mm	24	600	24	600
	5	Power	Electric	36-Volt / 48-Volt			
	6	Operator Type		Sit-down Rider Counterbalanced			
Dimensions	7	Tire Type		Cushion			
	8	Wheels (x = driven)	Number Front/Rear	2x/2			
	9	Mast (See Mast Chart)	Lifting Height (MFH) in mm	180	4570	171	4340
			Free Lift Height in mm	32.2	815	32.2	815
	12	Fork Carriage		ITA Class III			
	13	Forks	Standard L x W x T in mm	36x5x1.8	915x127x46	36x5x1.8	915x127x46
			Optional Lengths in mm	40, 42, 48, 54, 60, 72	1015, 1065, 1220, 1370, 1525, 1825	42, 48, 60, 72, 84	1065, 1220, 1525, 1825, 2135
	14	Tilt	F° / B° degree	5 / 5			
			Interlocked Fork Height** in mm	66	1675	66	1675
		Battery Compartment	Nominal in mm	36	914	36	914
	15	Headlength	Length to Fork Face in mm	91.0	2315	91.0	2315
	16	Width Overall	Standard Tread in mm	45.7	1160	45.7	1160
			Wide Tread in mm	48	1220	48	1220
	17	Height with Load Backrest	Mast Collapsed in mm	83	2105	83	2105
	18		Mast Extended in mm	228	5795	219	5565
	20	SIP to Bottom of OHG (86" [2184 mm] Tall OHG)	Std / Suspension in mm	36.1/35.8	918/910	36.1/35.8	918/910
	21	Turning Radius	in mm	77.7	1975	77.7	1975
	22	Load Distance	Center of Wheel to Fork Face in mm	16.1	410	16.1	410
	23	Aisle Width (Add Load + Clear)	Right Angle Stack in mm	93.8	2385	93.8	2385
	Performance	24	Speed Travel	Empty / Loaded 48V mph km/h	12.3/11.0	19.7/17.7	12.3/11.0
Empty / Loaded 36V mph km/h				11.0/10.0	17.7/16.1	11.0/10.0	17.7/16.1
25		Speed Lift†	Empty / Loaded 48V fpm mm/s	115/92	584/467	115/80	584/408
	Empty / Loaded 36V fpm mm/s		115/64	584/327	115/58	584/295	
26	Speed Lower	Empty / Loaded (Manual Hyd) fpm mm/s	90	460	90	460	
		Empty / Loaded (EPV Hyd) fpm mm/s	100	505	100	505	
Weights	32	Weight, Less Battery	lb kg	8375	3800	9035	4100
	33	Axle Load with Max Battery, Loaded	Front lb kg	15350	6962	16375	7423
			Rear lb kg	3275	1488	3410	1552
	34	Axle Load with Max Battery, Unloaded	Front lb kg	4951	2248	5110	2320
Rear lb kg			7674	3482	8175	3710	
Chassis	36	Tires	Size Front in mm	21x8x15	533x203x381	21x8x15	533x203x381
			Size Rear in mm	16x6x10.5	406x152x267	16x6x10.5	406x152x267
	38	Wheelbase	in mm	54.7	1390	54.7	1390
	39	Tread/Track Width	Front Standard / Rear in mm	37.9/36	965/914	37.9/36	965/914
			Front Optional / Rear in mm	39.5/36	1005/914	39.5/36	1005/914
	40	Ground Clearance, Loaded	Lowest Point in mm	3	76	3	76
	41		Center of Wheelbase in mm	4.8	122	4.8	122
	42	Grade Clearance, Loaded	%	35		35	
43	Brakes	Service	Foot Motor - Electric Assist				
		Parking	Auto - Electric				
Battery	44	Battery††	Type	Lead Acid			
			Capacity - 36V 5hr Rating @ 30°C	1615		1615	
	46		Capacity - 36V 6hr Rating @ 25°C AH	1650		1650	
			kWh	57.9		57.9	
			Capacity - 48V 5hr Rating @ 30°C	1180		1180	
			Capacity - 48V 6hr Rating @ 25°C AH	1210		1210	
			kWh	56.6		56.6	
			Weight - Min lb kg	3100	1410	3100	1410
			Weight - Max lb kg	4250	1930	4250	1930
			Size - Max	Length	36.38	924	36.38
		Width	38.69	983	38.69	983	
		Height	22.25	565	22.25	565	
		Cable Lead Length/Connector Pos. in mm	18/A	455/A	18/A	455/A	
48	Battery Floor Height	With Rollers / w/o Rollers in mm	17.4/17.1	442/434	17.4/17.1	442/434	
Motors	49	Motors	Dual Tractor Motors, dia in mm	8.9	225	8.9	225
	50		Lift Motor, dia in mm	7.2	183	7.2	183
	51	Operating Pressure	For Attachments psi bar	Up to 3000	Up to 207	Up to 3000	Up to 207

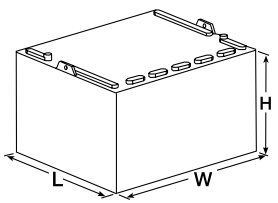

* Optional masts, attachments, longer load dimensions and higher lifting heights may result in derating of the capacity. Contact local dealer.

** Forward tilt restricted to 2° above this height.

† Based on TT mast.

†† With maintenance-free batteries or batteries with a lid (flat top), consult factory.

FC 5200 Series

Specifications

Mast Chart FC 5200-40/50/55			TL TRUCKERS MAST										
Dimensions	9	Lifting Height	in mm	68	1725	76	1930	80	2030	82	2080	112	2840
	11	Free Lift Height	in mm	5.8	145	5.8	145	5.8	145	5.8	145	5.8	145
	14	Interlocked Fork Ht	in mm	na	na	na	na	na	na	na	na	na	na
	17	Mast Collapsed Ht	in mm	54	1370	58	1470	60	1520	61	1545	76	1930
	18	Mast Extended Ht†	in mm	98	2489	106	2692	110	2794	112	2845	142	3607

Mast Chart FC 5200-40/50/55			TL																
Dimensions	9	Lifting Height	in mm	126	3200	138	3505	150	3810	155	3935	159	4040	170	4320	183	4650	194	4930
	11	Free Lift Height†	in mm	5.6	140	5.6	140	5.6	140	5.6	140	5.6	140	5.6	140	5.6	140	5.6	140
	14	Interlocked Fork Ht	in mm	78	1980	78	1980	78	1980	78	1980	78	1980	78	1980	78	1980	78	1980
	17	Mast Collapsed Ht	in mm	83	2105	89	2260	95	2410	101	2565	107	2720	113	2870	119	3025	125	3175
	18	Mast Extended Ht†	in mm	174	4420	186	4725	198	5030	203	5155	207	5260	218	5540	231	5870	242	6150

Mast Chart FC 5200-40/50/55			TF																
Dimensions	9	Lifting Height	in mm	114	2895	126	3200	138	3505	150	3810	162	4110	174	4415	184	4670	196	4975
	11	Free Lift Height†	in mm	26.2	665	32.2	815	38.2	970	44.2	1120	50.2	1275	56.2	1425	62.2	1580	68.2	1730
	14	Interlocked Fork Ht	in mm	60	1525	66	1675	72	1830	78	1980	84	2135	90	2285	96	2440	102	2590
	17	Mast Collapsed Ht	in mm	77	1955	83	2110	89	2260	95	2415	101	2565	107	2720	113	2870	119	3025
	18	Mast Extended Ht†	in mm	162	4115	174	4420	186	4725	198	5030	210	5335	222	5640	232	5895	244	6200

Mast Chart FC 5200-40/50/55			TT																
Dimensions	9	Lifting Height	in mm	188	4775	206	5230	216*	5485*	231*	5865*	246*	6245*	258*	6555*	276*	7010*	291*	7390*
	11	Free Lift Height†	in mm	32.2	815	38.2	970	44.2	1120	50.2	1275	56.2	1425	62.2	1580	68.2	1730	74.2	1885
	14	Interlocked Fork Ht	in mm	66	1675	72	1830	78	1980	84	2135	90	2285	96	2440	102	2590	108	2745
	17	Mast Collapsed Ht	in mm	83	2110	89	2260	95	2415	101	2565	107	2720	113	2870	119	3025	125	3175
	18	Mast Extended Ht†	in mm	236	5995	254	6450	264	6705	279	7085	294	7465	306	7775	324	8230	339	8610

Mast Chart FC 5200-40/50/55			QUAD										
Dimensions	9	Lifting Height	in mm	240*	6095*	258*	6550*	276*	7010*	294*	7465*	312*	7925*
	11	Free Lift Height†	in mm	31.8	805	39.8	1010	43.8	1110	49.8	1265	55.8	1415
	14	Interlocked Fork Ht	in mm	76	1930	82	2085	88	2235	94	2390	100	2540
	17	Mast Collapsed Ht	in mm	83	2105	89	2260	95	2410	101	2565	107	2720
	18	Mast Extended Ht†	in mm	288	7315	306	7775	324	8230	342	8690	360	9145

* Wide tread drive tires recommended. Refer to capacity charts.

† Includes 48" (1220 mm) high load backrest.

FC 5200 Series

Specifications

Mast Chart FC 5200-60			TL TRUCKERS MAST								
Dimensions	9	Lifting Height	in mm	60	1520	68	1725	72	1825	100	2540
	11	Free Lift Height	in mm	5.8	145	5.8	145	5.8	145	5.8	145
	14	Interlocked Fork Ht	in mm	na	na	na	na	na	na	na	na
	17	Mast Collapsed Ht	in mm	54	1370	58	1470	60	1520	74	1875
	18	Mast Extended Ht†	in mm	96	2438	104	2642	108	2743	136	3454

Mast Chart FC 5200-60			TL												
Dimensions	9	Lifting Height	in mm	118	2995	130	3300	142	3605	150	3810	159	4040	170	4320
	11	Free Lift Height†	in mm	5.9	150	5.9	150	5.9	150	5.9	150	5.9	150	5.9	150
	14	Interlocked Fork Ht	in mm	78	1980	78	1980	78	1980	78	1980	78	1980	78	1980
	17	Mast Collapsed Ht	in mm	83	2105	89	2260	95	2410	101	2565	107	2720	113	2870
	18	Mast Extended Ht†	in mm	166	4220	178	4525	190	4830	198	5030	207	5260	218	5540

Mast Chart FC 5200-60			TF														
Dimensions	9	Lifting Height	in mm	108	2740	120	3045	132	3350	143	3630	155	3935	167	4240	177	4495
	11	Free Lift Height†	in mm	26.2	665	32.2	815	38.2	970	44.2	1120	50.2	1275	56.2	1425	62.2	1580
	14	Interlocked Fork Ht	in mm	56	1420	62	1575	68	1730	74	1880	80	2030	86	2185	92	2335
	17	Mast Collapsed Ht	in mm	77	1955	83	2105	89	2260	95	2410	101	2565	107	2720	113	2870
	18	Mast Extended Ht†	in mm	156	3960	168	4265	180	4570	191	4850	203	5155	215	5460	225	5715

Mast Chart FC 5200-60			TT												
Dimensions	9	Lifting Height	in mm	180	4570	198	5025	208*	5280*	223*	5660*	238*	6045*	250*	6350*
	11	Free Lift Height†	in mm	32.2	815	38.2	970	44.2	1120	50.2	1275	56.2	1425	62.2	1580
	14	Interlocked Fork Ht	in mm	62	1575	68	1730	74	1880	80	2030	86	2185	92	2335
	17	Mast Collapsed Ht	in mm	83	2105	89	2260	95	2410	101	2565	107	2720	113	2870
	18	Mast Extended Ht†	in mm	228	5795	246	6250	256	6505	271	6885	286	7265	298	7570

* Wide tread drive tires recommended. Refer to capacity charts.

†Includes 48" (1220 mm) high load backrest.

FC 5200 Series

Specifications

Mast Chart FC 5200-65			TL TRUCKERS MAST							
Dimensions	9	Lifting Height in mm	57	1445	65	1650	69	1750	97	2465
	11	Free Lift Height in mm	5.8	145	5.8	145	5.8	145	5.8	145
	14	Interlocked Fork Ht in mm	na	na	na	na	na	na	na	na
	17	Mast Collapsed Ht in mm	54	1370	58	1470	60	1520	74	1875
	18	Mast Extended Ht† in mm	93	2362	101	2565	105	2667	133	3377

Mast Chart FC 5200-65			TL											
Dimensions	9	Lifting Height in mm	115	2920	126	3200	139	3530	150	3810	159	4040	170	4320
	11	Free Lift Height† in mm	5.9	150	5.9	150	5.9	150	5.9	150	5.9	150	5.9	150
	14	Interlocked Fork Ht in mm	78	1980	78	1980	78	1980	78	1980	78	1980	78	1980
	17	Mast Collapsed Ht in mm	83	2105	89	2260	95	2410	101	2565	107	2720	113	2870
	18	Mast Extended Ht† in mm	163	4140	174	4420	187	4750	198	5030	207	5260	218	5540

Mast Chart FC 5200-65			TF													
Dimensions	9	Lifting Height in mm	105	2665	117	2970	129	3275	141	3580	153	3885	165	4190	175	4445
	11	Free Lift Height† in mm	26.2	665	32.2	815	38.2	970	44.2	1120	50.2	1275	56.2	1425	62.2	1580
	14	Interlocked Fork Ht in mm	56	1420	62	1575	68	1730	74	1880	80	2030	86	2185	92	2335
	17	Mast Collapsed Ht in mm	77	1955	83	2105	89	2260	95	2410	101	2565	107	2720	113	2870
	18	Mast Extended Ht† in mm	153	3885	165	4190	177	4495	189	4800	201	5105	213	5410	223	5665

Mast Chart FC 5200-65			TT											
Dimensions	9	Lifting Height in mm	171	4340	189	4800	199	5055	214	5435	229	5815	241	6120
	11	Free Lift Height† in mm	32.2	815	38.2	970	44.2	1120	50.2	1275	56.2	1425	62.2	1580
	14	Interlocked Fork Ht in mm	62	1575	68	1730	74	1880	80	2030	86	2185	92	2335
	17	Mast Collapsed Ht in mm	83	2105	89	2260	95	2410	101	2565	107	2720	113	2870
	18	Mast Extended Ht† in mm	219	5565	237	6020	247	6275	262	6655	277	7035	289	7340

* Wide tread drive tires recommended. Refer to capacity charts.

†Includes 48" (1220 mm) high load backrest.

Standard Features

1. Crown's Access 1 2 3® Comprehensive System Control
2. Intrinsic Stability System™
 - Travel speed reduction and appropriate brake control when forks are above free lift
 - Forward tilt interlock above free lift
 - Counterweight designed for optimal stability
 - Ramp speed control
 - Cornering speed control
 - Hill hold
3. e-GEN® braking system with automatic parking brake
4. Operator entry/exit
 - 18" (460 mm) step height
 - Large entry/exit "window"
 - Tubular overhead guard upright for easy hand hold
 - Contoured battery seat deck
 - Rounded floorboard edges
 - Tilt steering wheel and sculpted column
 - Large, uncluttered floorboard
5. Operator compartment design features
 - Low cowl for fork and floor visibility
 - Wide visibility window between overhead guard and front pillars
 - Crown FlexSeat™- fabric with hip restraint and anti-cinch seatbelt.
 - Infinite adjustment steering wheel column
 - Nylon control handles with tactile feedback
 - Natural position for forward/reverse selector
 - Rubber floor mat/rubber covered pedals
 - Sculpted counterweight for rearward visibility
6. Crown-manufactured drive and lift motors
7. 36/48-volt system

8. Crown display
 - Battery discharge indicator with lift interrupt and re-key feature
 - Hour meters/travel distance/stop watch
 - Pin code access capable
 - Event code display with five (5) key navigation
 - Access 1 2 3 diagnostics
 - P1, P2, P3 Performance tuning
 - Forward/reverse indicator
9. High visibility mast with in-line hose routing
10. Waterfall design overhead guard
11. Lift out or side removal battery access
12. Battery side retainer with interlock and fault identification
13. No tool lift out floorboards
14. 48" (1220 mm) high load backrest
15. 350 amp battery connector
16. Color-coded wiring
17. InfoPoint® System with Quick Reference Guide
18. Three-spool valve
19. O-ring face seal hydraulic fittings
20. Battery disconnect handle
21. Lift interrupt
22. AC hydraulics and on-demand steering

Optional Equipment

1. Integral or hook on sideshifter
2. Freezer and corrosion conditioning
3. UL "EE" rating
4. Quick Charge (1 or 2 connectors on seatdeck)
5. InfoLink® Ready System
6. TL, TF and Quad mast styles
7. TL Truckers Mast
8. Polished and tapered forks
9. Fork lengths
10. Hydraulic valves for attachments
11. Quick disconnect hydraulic connectors
12. Attachment pressure regulator and gauge
13. Special forward tilt
14. Adjustable armrest
15. Steering spinner knob

16. Keyless on/off switch
17. Work lights
18. Storage tray with clipboard support
19. Suspension Seat - fabric or vinyl
20. Tilt Position Assist
21. Back-up, brake and tail lights
22. Strobe lights
23. Audible travel alarm
24. Tow pin
25. Brake activated traction cutout
26. Foot operated directional control
27. Full battery side doors
28. Battery compartment rollers
29. Pos/Neg accessory cable
30. Wide tread widths
31. Load backrest heights
32. Drive-in rack overhead guard
33. Non-marking smooth or lug rubber tires
34. Work Assist® Accessories
 - Clip Pad
 - Hook
 - Storage Net
 - Storage Bin
 - Seat Deck Clip
 - Accessory clamp
 - Terminal mounting
 - Fire extinguisher
 - Operator fan
 - Work lights
 - Mirrors
 - Shrink wrap holder
 - Cup holder
 - Pencil holder
35. Battery spacer
36. Crown FlexSeat - vinyl
37. Rear post handle with horn button
38. Fingertip or dual joystick hydraulic controls
39. Swivel Seat
40. Lights on with Keyswitch
41. Attachments:
 - Carton Clamp
 - Fork Positioner
 - Push Pull
 - Single/Double
42. OHG Covers
 - Plexi-glass
 - 2x2 wire mesh

Driveability

The FC 5200 benefits from Crown's design and engineering excellence. Numerous features improve operator comfort and productivity.

A low 18" (460 mm) step height first greets the operator. A low, streamlined battery cover helps the operator glide into the truck's seat. The overhead guard is shaped to open up the entry/exit window and its tubular design provides a comfortable hand grip location for a variety of operator heights. The compact tilt steer column and steer wheel further facilitate entry/exit. Tilt column is spring loaded to easily move up and away. Floorboard is uncluttered and rubber covered to insulate the operator from vibration. Sculpted floorboard design promotes visibility to the drive tires, which can reduce product and pallet damage. Brake pedal effort is reduced. Pedal to pedal and floor to pedal relationships are refined for comfort.

Better visibility can be seen everywhere you look. A low cowl for fork and carriage visibility, a high visibility mast, a compact steer column, a sculpted floorboard and a "waterfall" overhead guard all contribute to superior visibility.

Control handles are crafted into the compartment and "fanned" for easy selection. They include tactile feedback for comfort and easy selection. Control actuation forces are minimal and responsive.

Battery disconnect is easy to reach and operate. Easy to actuate rocker-type switches are conveniently located to select optional work lights or fan. A large convex horn button is housed in the center of the wheel.

Crown Drive System

Crown has applied the latest generation AC drive system, enhanced with Access 1 2 3® technology. Crown-manufactured, independently controlled, AC drive motors are specifically designed to optimize system integration between the traction and braking controls. The demand for high efficiency systems that closely match customer torque requirements is met with this generation control system.

Crown's Access 1 2 3 technology provides optimum performance and control by offering a communication interface for both operators and technicians, intelligent coordination of lift truck systems and simplified service with advanced diagnostics.

The Crown display is used for easy troubleshooting, access event history and set performance features. A distribution panel is conveniently located with all test points, control fuses and central wiring for easy troubleshooting.

Three modes of performance can be selected to accommodate operator experience or application requirements.

e-GEN® Braking System

Variable regenerative motor braking is optimized and assisted with electric friction brakes, eliminating maintenance associated with typical wet, disk or drum and shoe style brakes. The appropriate amount of stopping force is applied to match operator brake input and the current operating conditions of the truck.

The closed loop Access 1 2 3 traction control will keep the truck static until a travel input is requested, even when operating on a grade.

Automatic electric parking brakes activate when the operator leaves the seat, a travel input has not been requested or battery power has been disconnected.

Steering System

Full hydrostatic system with equal area, double-acting cylinder provides equally responsive steering rate both ways (4.8 turns lock to lock). Rugged axle frame; forged spindle and connecting links eliminate the need for adjustment. One-piece forged

spindle and kingpin in tapered roller bearings for improved life and serviceability. Spherical bearings with tapered pins in connecting links eliminate any play in linkage. All bearing locations are sealed to exclude contaminants and are equipped with lubrication fittings for ease.

Load-sense hydrostatic steering is an on-demand system which reduces energy consumption. Smooth, quiet steering control with minimal operator effort required at the steer tiller.

The steering geometry is matched to the controller to deliver smooth steering at all angles. The advantage is less tire scrubbing which extends tire life.

Both motors receive power, even in the tightest turns. This helps the truck to accelerate, turn and maneuver even from a full turn start position.

Cornering speed control regulates the drive motor's output by the turning degree of the truck. The advantage is smooth, stable steering which may increase operator confidence and productivity.

Hydraulics

Premium hydraulic function control valve provides precise metering of lift, tilt and accessory functions. Compensating section in the valve provides repeatable function speed regardless of load condition. Hydraulic lever actuation is minimal, reducing stress. Compensating section also improves overall system efficiency.

Tilt compensator prevents tilt from lunging or speeding up when doing simultaneous functions.

Crown lift/tilt interlock system provides extended forward tilt at low fork heights, reduced forward tilt at elevated heights to improve truck stability when forks are elevated.

The control valves' modular design allows easy addition of accessory functions. Maximum lowering speed is limited by pressure compensating flow control valve and velocity fuses. Integrated hydraulic cylinder cushions soften mast staging. All lift cylinder rams are plated and retract into the hydraulic oil for additional corrosion protection when forks are lowered.

The steel oil reservoir is integral to the frame which helps to dissipate hydraulic oil heat. This clean, leak-free design includes suction strainer with separate, easily accessible fill port and dipstick with filtered breathers. Oil is returned through a replaceable spin-on type oil filter. The hydraulic system provides continuous filtration.

Crown Manufactured Mast Assembly

The mast has four points of attachment to the truck for good load force distribution. Two mounting points are at the frame, where tilt cylinders attach. Tilt cylinders use spherical bushings to resist off center load distortions. Two large diameter studs secure the mast to the drive units.

High visibility mast features nested-rail design with lift cylinders positioned behind the rails. Heavy-duty mast is engineered to provide smooth reliable operation. Large hydraulic hose reeves and hose placement are engineered to reduce hose wear and increase hose life. Hose routing places hoses in-line versus side-by-side to reduce visual interference. Large lift chains are used for long reliable service life. Large diameter lift cylinders provide smooth operation.

Optional TL, TF and quad mast is available.

Batteries

Battery deck lid releases easily to expose battery for lift out or side battery removal. Optional battery rollers for use with mechanized extraction equipment. A low battery side retainer is standard. Full battery side doors are optional.

Carriage

An ITA Class II or III is standard. An optional Crown integral sideshifter and hook on type ITA sideshifters or other attachments can be easily added. Optional fork lengths are available.

Drive Units

Two Crown-manufactured independent double reduction planetary gear drive offers 22 to 1 gear reduction. The first and second reduction use helical gears for low-noise and efficiency. The drive unit gears are splash lubricated in an oil bath.

Other Options

1. Audible travel alarm
2. Flashing lights

Safety considerations and dangers associated with audible travel alarms and flashing lights include:

- Multiple alarms and/or lights can cause confusion.
- Workers ignore the alarms and/or lights after day-in and day-out exposure.
- Operator may transfer the responsibility for "looking out" to the pedestrians.
- Annoys operators and pedestrians.

Other Options Available

Contact your local Crown dealer.

Dimensions and performance data given may vary due to manufacturing tolerances. Performance is based on an average size vehicle and is affected by weight, condition of truck, how it is equipped and the conditions of the operating area. Crown products and specifications are subject to change without notice.



You can count on Crown to build lift trucks designed for safe operation, but that's only part of the safety equation. Crown encourages safe operating practices through ongoing operator training, safety-focused supervision, maintenance and a safe working environment. Go to crown.com and view our safety section to learn more.

Crown Equipment Corporation
 New Bremen, Ohio 45869 USA
Tel 419-629-2311
Fax 419-629-3796
 crown.com

Because Crown is continually improving its products, specifications are subject to change without notice.

Crown, the Crown logo, the color beige, the Momentum symbol, Access 1 2 3, e-GEN, InfoPoint, Intrinsic Stability System, FlexSeat, InfoLink and Work Assist are trademarks of Crown Equipment Corporation.

Copyright 2016-2017 Crown Equipment Corporation
 SF19377 Rev. 12-17
 Printed in U.S.A.